

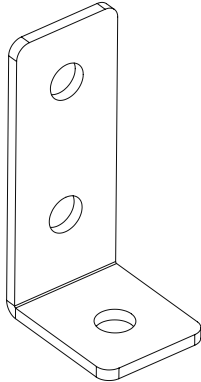

4182CD



Finishes: HDG, SS304, SS316

Characteristics:

- Metallic
- Non-flame propagating component
- Electrically conductive component
- With metallic coating. Resistance to corrosion:

HDG: class 6 SS304: class 9A SS316: class 9B

INSTRUCTIONS FOR USE

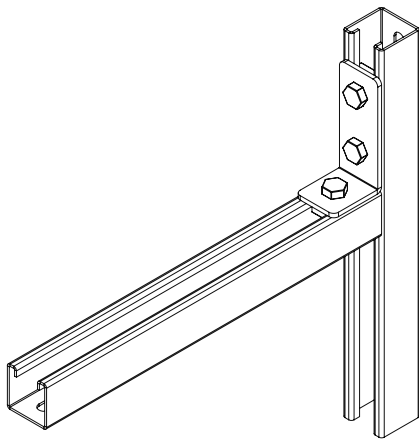

- Piece 4182CD allows the assembly of two profiles in an angle of 90° by using bolts and spring nuts.
- To join profiles with 4182CD, 3 M10 (or M8) spring nuts and 3 M10x30 DIN 933 Bolts (or 3 M8x30 DIN 933 + 3 M8 DIN 9021 washers) are required.
- It is usually assemble together with other accessories of the BASORPERFIL 41/82 family for the construction of RACKS and supports to fix cable trays in galleries and tunnels.

SAFE WORKING LOAD

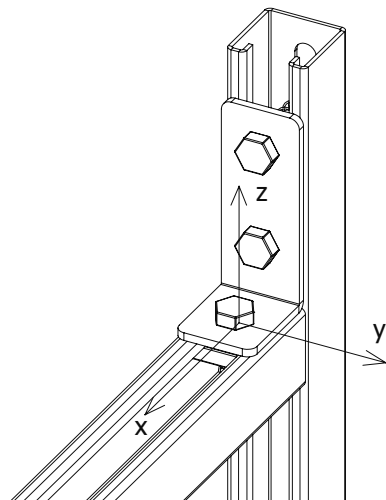

ADMISSIBLE EFFORTS					
4182C	Mx	My	Fx	Fy	Fz
	kg.m	kg.m	kg	kg	kg
	+16	+36	1150	300	535
-16	-7				

Declared values include 1.7 safety factor as requested in EN IEC 61537 for cable tray supports.

If the assembly is done using spring nuts, Fx and Fz load values are limited by the maximum traction/sliding values of the spring nut (350/700 kg).

Related products:

BASORPERFIL 41/82 profiles and accessories.